

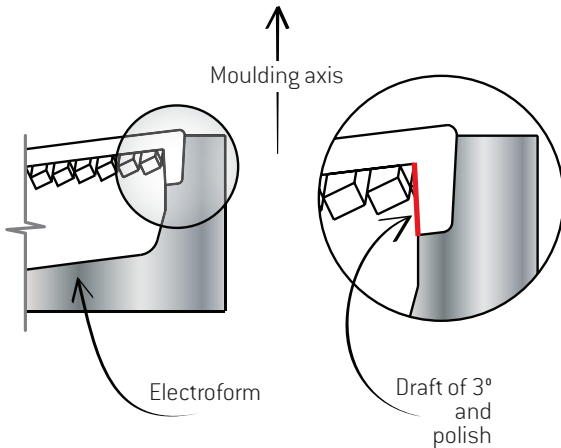

FITTING AN ELECTROFORM

POCKET WITHOUT A STEEL BAND

After fitting the electroform, add a draft of 3° and then polish.



POCKET WITH A STEEL BAND

The pocket's lateral wall must have a draft of 3°. It must be polished to a height equivalent to the height of the prisms.

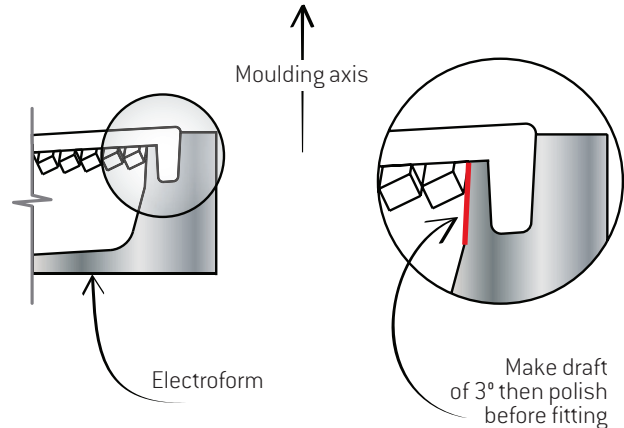

FITTING AT SLIDE LINE

The electroform mounted on the slide must be higher than the electroform mounted on the core by about 0.25 mm (0.010").

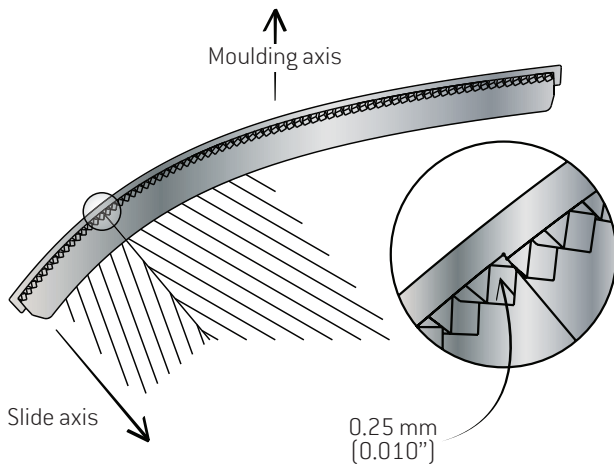

FITTING IN A POCKET

To ensure interchangeability, remove material on the contour of the electroform.

IMPORTANT: TO PREVENT IRREVERSIBLE DAMAGE 90% of the electroform's back surface is in contact with the bottom of the pocket.

There is a maximum gap of 0.05 mm (0.003") between the electroform and its pocket.

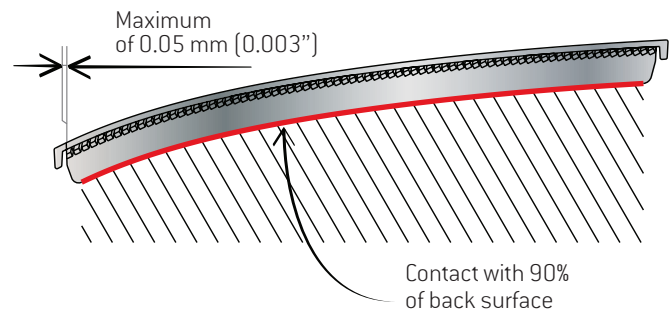

ATTENTION

Electroforms are fragile mould components and may sustain visible or invisible damage if not handled and used with care.

When in doubt, please contact DBM Reflex.